

Panasonic
ideas for life

2010 / early
Professional Plasma Displays

Panasonic ideas for life



panasonic.net/proplasma

Simulated pictures on screen.
Specifications are subject to change without notice. Printed in Japan
CT10PDP-W01

Expressive Power for Natural, Lifelike Images, Plus Flexible Expandability with the Slot 2.0

Panasonic's proud NeoPDP technology achieves both high image quality and low power consumption, while new professional-grade designs build in easy expandability, which is a key requirement for commercial use. On top of that, our durable displays for digital signage and presentation use also take the environment into full consideration. Presenting the all new 20 Series.



NeoPDP Technology



A newly developed cell structure, an innovative drive technology, a new discharge gas and a revamped panel have four times luminous efficiency*1 compared to our 2007 models.

*1: On the PF20 Series only. Comparing existing FULL-HD models with 2007 Panasonic models of the same screen size.

The Wide Range of Input Terminals and SLOT 2.0



Greater display convenience and system flexibility are gained with standard HDMI and DVI terminals and a PLink™-compliant network function.

Environmentally Friendly Panel



Mercury and Lead Free Plasma Display Panel

Panasonic products are more friendly to the environment. All plasma display panels are mercury and lead free. This reduces the impact on the environment when recycling or disposing of them in the future.

Long Panel Life, Up to 100,000 Hours

Panasonic plasma display panel offers a long life of up to 100,000 hours, under normal operating condition – providing gorgeous HD images for many years.

FULL HD Plasma Displays



TH-103PF12W TH-85PF12W TH-65PF12WK TH-58PF12WK

PF12 series NeoPDP PLink NANODRIFT

FULL HD Plasma Displays

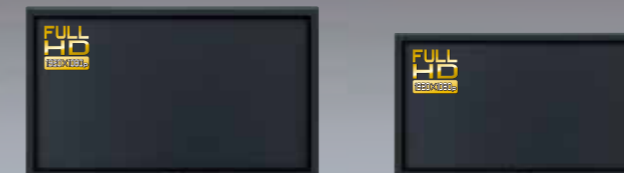

TH-50PF20W TH-42PF20W

PF20 series NeoPDP PLink SLOT 2.0 NANODRIFT

High Definition Plasma Displays

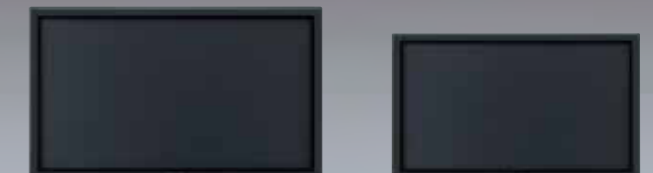

TH-50PH20W TH-42PH20W

PH20 series SLOT 2.0 NANODRIFT



Newly Developed Panel Reproduces Exceptional Detail Over the Entire Large Screen

NeoPDP Technology Increases Luminous Efficiency by About 4x for Greater Image Quality

Plasma displays illuminate their pixels with the following three steps.

1. An electric discharge is used to generate ultraviolet rays.
 2. The ultraviolet rays illuminate phosphors.
 3. The light from the phosphors is emitted from the panel.
- The NeoPDP technology further improves the efficiency of all of these steps to achieve about four times*¹ the luminous efficiency of our 2007 models. This results in better image quality and saves more power.

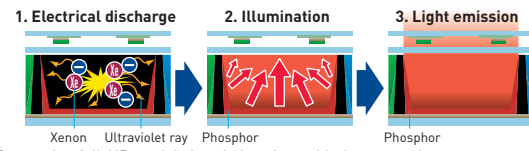

*1: Comparing full-HD models in existing sizes with the same-size 2007 Panasonic models.
*2: The PF12 Series achieves about two times the luminous efficiency of our 2007 models.

Newly developed panel

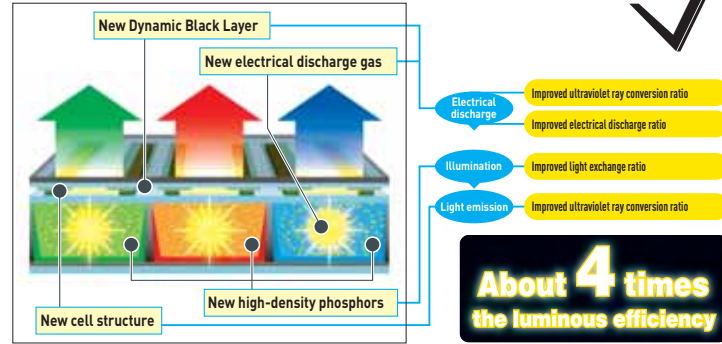

**About 4 times
the luminous efficiency**



Native Contrast of 5,000,000:1*²

To take maximum advantage of the inherently superior black expression of self-illuminating plasma displays, the newly developed panel allows the PF20 Series to emit light without the use of a pre-discharge. Its high contrast teams up with deeper black reproduction — which forms the basis of image expression — to render rich textures in images with subtle shading and colour differences.

*2: The dark room contrast ratio of the panel unit that can be displayed simultaneously on the same screen. Measured in "Dynamic" picture mode using a white signal in a 4% window.

*3: The PF12 Series has 40,000:1 contrast ratio.

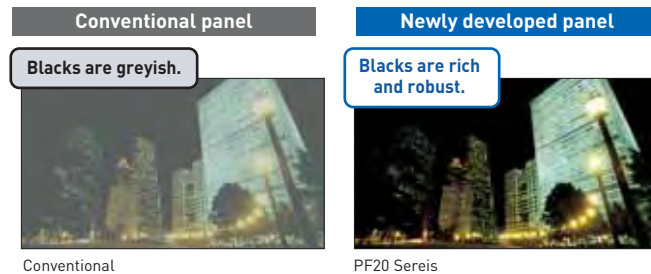

Rich, Expressive Gradation of 6,144 Equivalent Steps

Panasonic plasma displays achieve rich shading with an incredibly accurate 6,144 equivalent steps of gradation in all scenes. These displays deliver richer gradation from brilliant whites to robust blacks, and faithfully reproduce the textural quality of the original video source.

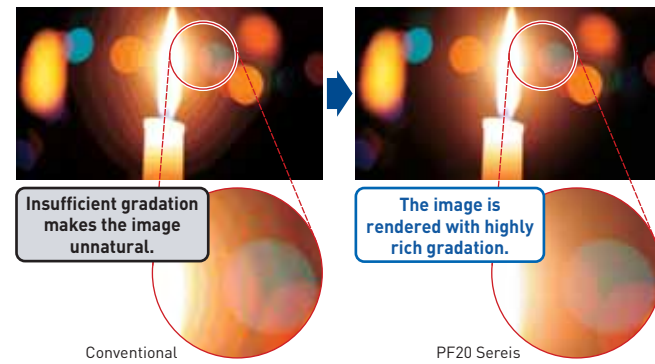

Approx. 110%*³ of the Colour Gamut of the HDTV Standard

High-definition broadcasts are based on the HDTV standard, rather than the conventional PAL standard. Panasonic plasma displays reproduce a wide colour gamut exceeding the entire colour range specified in the HDTV standard (ITU-R, BT.709). This results in a natural and faithful colour reproduction on a large screen. Digital Colour Reality technology also assures images with immaculate details.

*3: Comparison based on colour gamut



Tough Body with Impact-Resistant Front Glass Panel

The front of the plasma display is covered by a hard glass panel that provides strong resistance to impact and breakage, thereby providing extra assurance against damage when used in busy public spaces. It virtually eliminates any need for additional protective covering.



Minimal Maintenance

Cleaning is simple, as dust and dirt can easily be wiped away with a soft cloth. Panasonic plasma displays provide stunning pictures, have a long service life, and require minimal maintenance.

Moving Picture Resolution of 1,080 Lines for Sharp and Clear Display of Fast-motion Images

The superb moving picture resolution of the plasma display panel ensures that even fast-moving action is displayed clearly, with full detail and with fewer after-images. Panasonic plasma displays deliver beautiful, high-resolution images from 1080p Full HD sources.

* Moving picture resolution is a quantitative measurement of detail in displayed motion pictures discernible by the human eye. Using a measurement method developed and applied by the APDC (Advanced PDP Development Center Corporation).

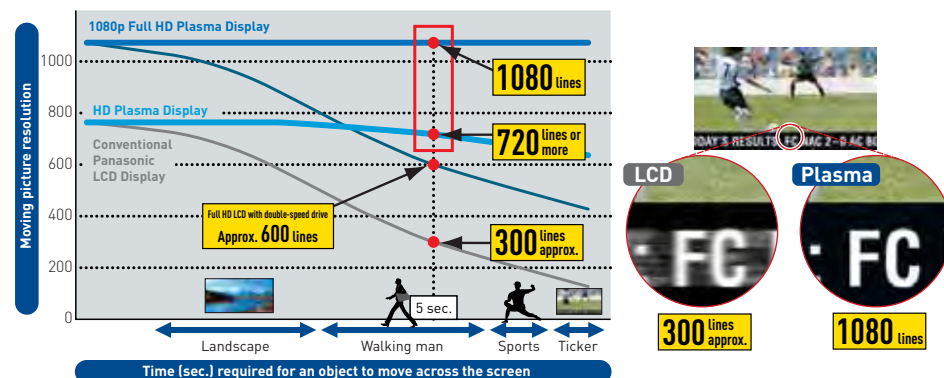

Dynamic Images Viewed from Any Angle

Panasonic plasma display panels use self-illuminating pixels to provide more vivid colour and sharper images that never appear faded, even when viewed at an angle. Panasonic plasma displays deliver high-resolution images without losing the quality of the original video source.

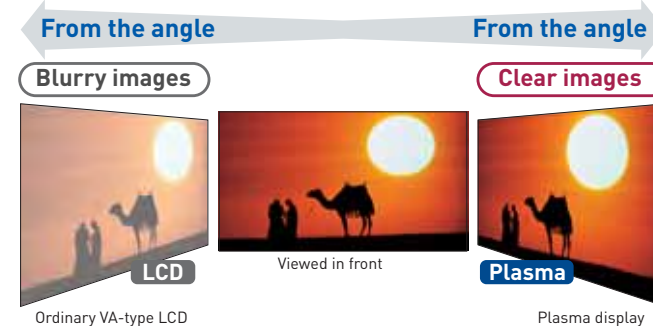

Long Life of up to 100,000 Hours*⁴

The Panasonic plasma display panel offers a long life of approximately 100,000 hours*⁴, under normal operating conditions — providing gorgeous HD images for many years.

Long Life for Vertical Installations Too

Panasonic plasma displays can also be set up in a vertical format, allowing for more efficient use of limited space configurations. The long life of approximately 100,000 hours*⁴ and superb image quality are completely unaffected by vertical installation. When the portrait mode is selected in the initial display settings, the on-screen display rotates 90-degrees for easy reading. The cooling fan control also changes automatically for portrait mode.

*4: Guideline operating hours before the panel brightness is reduced to half when the panel is used to display motion pictures in the Standard mode. Afterimages (burned-in images) and malfunctions are not taken into consideration.



Rich Gradation Raises the Quality of Digital Signage with Faithful, High-Contrast Image Reproduction

Tough Body with Impact-Resistant Front Glass Panel Withstands Use in Public Spaces

The front of the plasma display is covered by a hard glass panel that provides strong resistance to impact and breakage, thereby providing extra assurance against damage when used in busy public spaces. It virtually eliminates any need for additional protective covering.

Minimal Maintenance

Cleaning is simple, as dust and dirt can easily be wiped away with a soft cloth. Panasonic plasma displays provide stunning pictures, have a long service life, and require minimal maintenance.

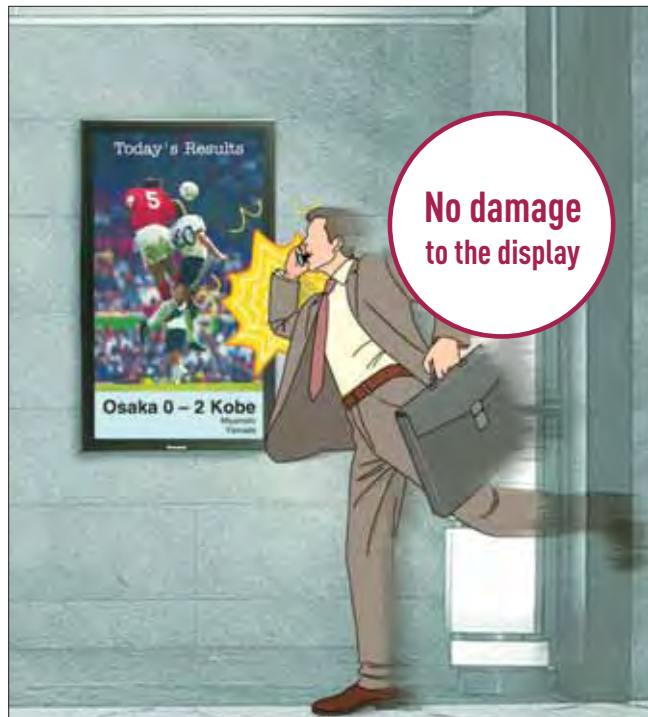

Long Life of up to 100,000 Hours*1

The Panasonic plasma display panel offers a long life of up to 100,000 hours*1, under normal operating conditions — providing gorgeous HD images for many years.

Long Life for Vertical Installations Too

Panasonic plasma displays can also be set up in a vertical format, allowing for more efficient use of limited space configurations. The long life of approximately 100,000 hours*1 and superb image quality are completely unaffected by vertical installation. When the portrait mode is selected in the initial display settings, the on-screen display rotates 90-degrees for easy reading. The cooling fan control also changes automatically for portrait mode.

*1: Guideline operating hours before the panel brightness is reduced to half when the panel is used to display motion pictures in the Standard mode. Afterimages (burned-in images) and malfunctions are not taken into consideration.

Dynamic Images Seen from Any Angle

Panasonic plasma display panels use self-illuminating pixels to provide more vivid colour and sharper images that never appear faded, even when viewed from an angle. Panasonic plasma displays deliver high-resolution images without losing the quality of the original video source.

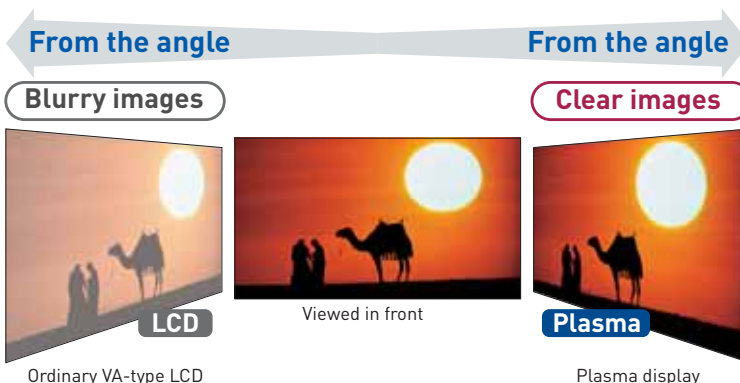
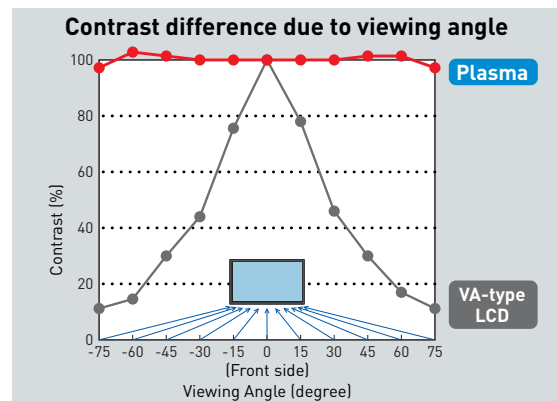

* Measurements obtained by Panasonic



Crisp Images with a Native Contrast of 2,000,000:1*2

Original image-processing technologies have enabled a high contrast ratio of 2,000,000:1*2. This produces robust blacks and gives images greater realism and depth.

*2: The dark room contrast ratio of the panel unit that can be displayed simultaneously on the same screen. Measured in "Dynamic" picture mode using a white signal in a 4% window.

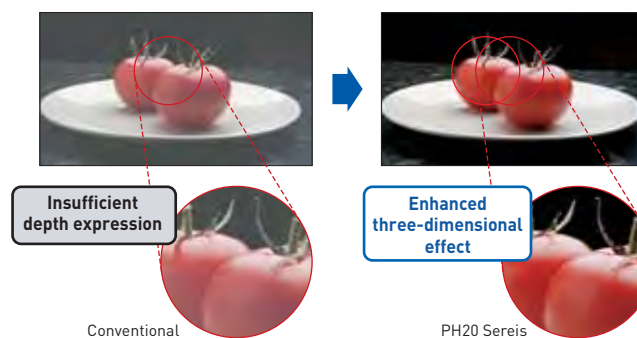

Rich, Expressive Gradation with 5,120 Equivalent Steps

Maximum 18-bit digital signal processing renders images with the equivalent of 5,120 steps of gradation, while suppressing noise and minimizing blocked shadows.

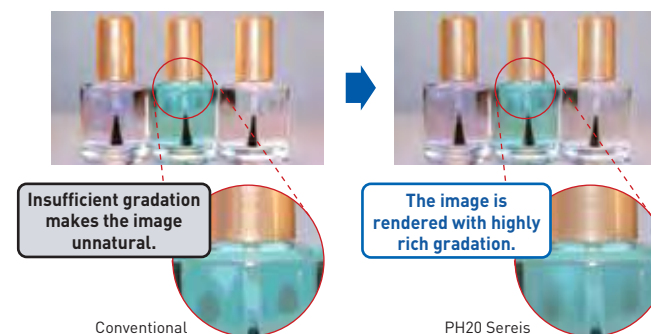

Sharp and Clear Fast-Motion Images

Panasonic pro plasmas handle fast-motion video in real time without motion blur or lag. The superior moving image picture resolution ensures that even fast-moving action is displayed clearly with full detail. Panasonic assures delivery of beautiful, high-resolution images from all HD sources.

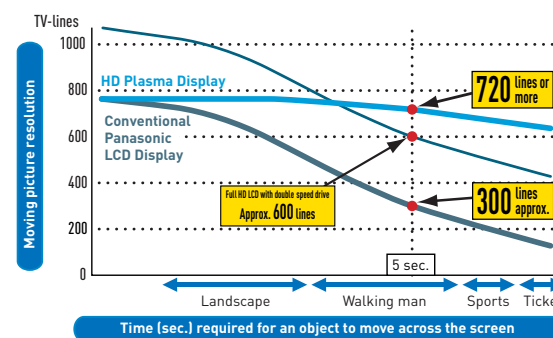

* Moving picture resolution is a quantitative measurement of detail in displayed motion pictures discernible by the human eye. Using a measurement method developed and applied by the APDC (Advanced PDP Development Center Corporation).

Colours Faithful to the Original

This wide colour gamut exceeds even the colour reproduction range of the HDTV standard (ITU-R, BT.709). The colours produced are more faithful to the original and appear more natural.

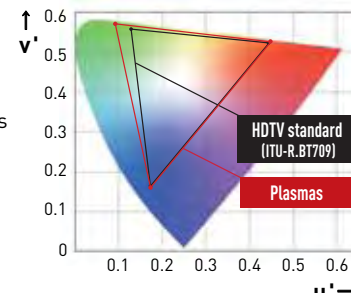

Numerous Image Display Functions and Utilities Enhance the Power of the Large-Screen Display

PJLink™*1-Compatible Network Function for Remote Control

This network function lets you operate displays by remote control and monitor their status through a LAN connection. Since it supports the "PJLink™*1 Class 1" industry standard, existing infrastructure can be used for effective plasma display operation. You can also control the display*2 from a web browser, making it even easier to use.

The network function also uses the same protocol as Panasonic projectors, so other video devices can be combined to upgrade the system.

*1: Unified standards for a telecommunications protocol for operating and managing multiple projectors.

*2: PF20 Series only.

• When using the network function, be sure to set "Control I/F Select" in "Network Setup" to "LAN."

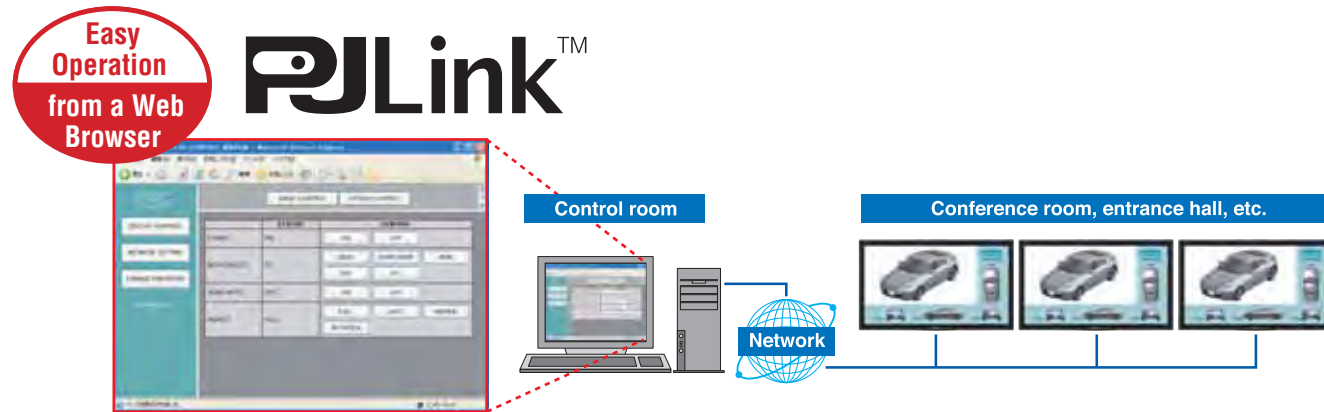

Conference systems utilized together with projectors.



Portrait Zoom Function Enlarges Horizontal Images for Vertical Display

By dividing horizontal content into three vertical segments, the Portrait Zoom function can dynamically display selected segments. Then, by grouping three 103-inch or 85-inch plasma displays together in portrait mode, a dynamic multi-screen system can be configured to display life-size people with almost the same field of view as the original content.

Horizontal content is divided into three segments.

Desired segments are displayed full-screen in portrait mode.

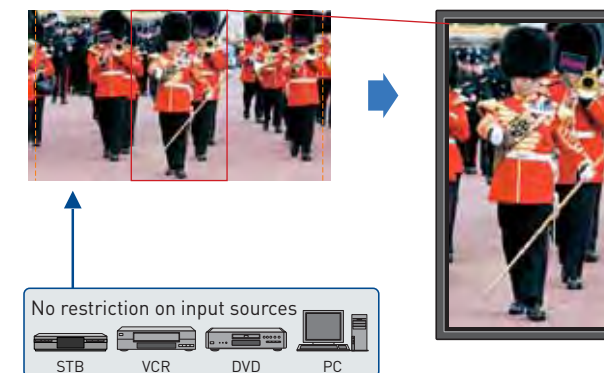

Multi-Screen System Dynamically Displays Images in Large Spaces

The Multi-Display function enlarges images up to five times their original size, both vertically and horizontally. It enlarges images by the same zoom ratio in both vertical and horizontal directions, such as 2x2, 3x3, 4x4 and 5x5, or by different ratios in order to effectively use vertically or horizontally elongated spaces. Plasma display versatility can be further enhanced by freely selecting the zoom ratio to match the installation space.

• Some degradation occurs when images are enlarged.
• Provide an appropriate air-conditioned environment because the ambient temperature varies depending on the installation condition and location.

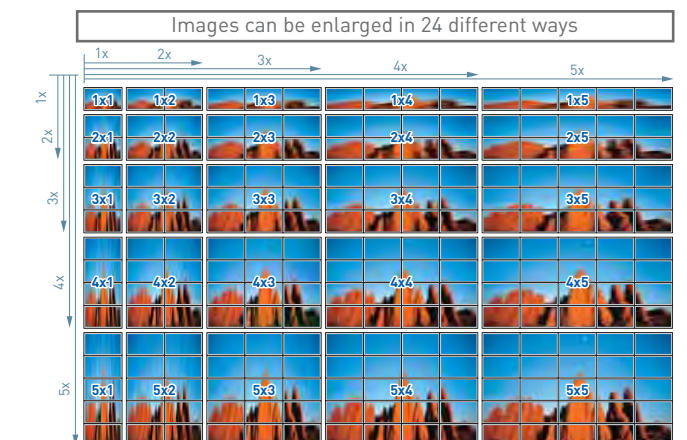

Effective Functions Used with Portrait Zoom or Multi Display

• Multi AI Control Function

By applying AI control to the brightness signal of the entire input signal using the same video processing as for a single-screen image, this function achieves a uniform brightness level over the entire image.

• Display ID Control

To prevent remote control errors that can occur when multiple displays are installed in close proximity, each display in a multi-screen system must have a unique ID. Assigning a display ID assures reliable remote control operation.

* The optional ID Remote Control Unit (EUR7636070R) is required for the TH-65PF12/58PF12/50PF20/42PF20/50PH20/42PH20.

• Power-On Delay Function

This function automatically shifts the power-on time slightly for each display unit in the system, so there's less load on the power supply.

• Seam Hides Video Off Mode

This mode displays a full-screen image, including edges (the entire width of the frame) of the display panel. This is especially suitable for displaying text information, since no words are hidden by the frame.

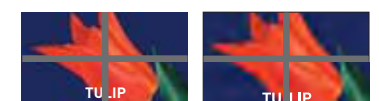

Advanced Functions and Utilities

Help Create Effective Signage and Presentation

Blend Dual Picture Function

The Blend Dual Picture function overlays text information produced with a PC onto base motion images. This function makes it easy to produce subtitles without requiring expensive editing equipment. And because the text data is displayed in full-HD image quality, corporate or brand images can be effectively presented in high resolution.

- Please note that using this function to process images without the permission of the copyright holder for commercial display or for public viewing may infringe upon the rights of the copyright holder.
- With the PF12 Series, analogue signal combinations cannot be displayed. Signal combinations are also limited with the PF20 Series.

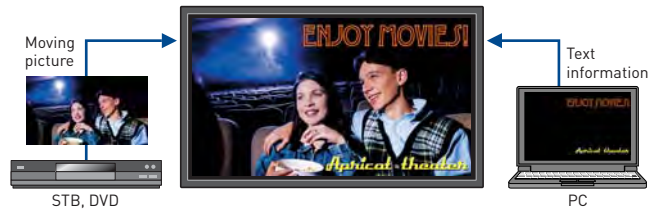

Dual Picture Mode

You can simultaneously display images from any two different AV sources connected. And you can select the audio output from either source. Playing back the audio from the sub-source can be useful in teleconferencing.

- Portrait Zoom, Multi Display or Digital Zoom function does not work in Dual Picture mode.
- With the PF12 Series, analogue signal combinations cannot be displayed. Signal combinations are also limited with the PF20 Series.

Advanced Dual Picture Mode

This mode lets you overlay a video image onto a full-screen PC image. You are now able to combine a video clip with any text information from a PC, giving you a more effective way to present important messaging.

- With the PF12 Series, analogue signal combinations cannot be displayed. Signal combinations are also limited with the PF20 Series.

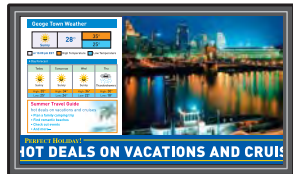

Motion images, text messages and tickers can be displayed.



Motion images in the 16:9 aspect ratio, text informations and tickers.



Motion images and text messages are arranged next to each other.



Motion images and tickers are combined.

4x Digital Zoom

This function lets you enlarge a portion of an image up to four times its normal size and display it on the full screen. This function can help give presentations greater impact.

- Digital Zoom does not work in Multi Display or Dual Picture mode.
- Some degradation occurs when images are enlarged.

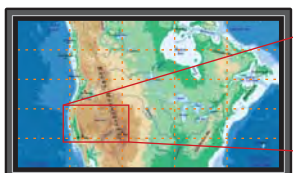

x 1



x 4

Picture Profiles

The picture adjustment values set using the Picture menu and advanced settings can be stored in the display's memory as profiles. Up to eight combinations can be stored, and the preferred profile can be selected to match the video source being used.

1:1 Pixel Mode

The 1:1 Pixel mode maps the 1920 x 1080 video content to Full HD panel pixels to display 100% of the original content. By skipping the scaling process, this mode is able to produce high-definition images in their original, 1:1 pixel form.

* Compatible signal format: 1,125/50i, 60i, 24sF, 24p, 25p, 30p, 50p, 60p, 1,250/50i

Monitor Mode

This mode displays images without changing the brightness within the same signal level range, even if the average picture level (APL) of the screen varies. Since this mode maintains white balance regardless of the size of bright areas in the image, it is suitable for use in broadcast stations and image production studios in which precise colour reproduction is required.

Display Size Setting

displays video signals so that the top, bottom, right and left screen edges that are usually cut off become visible.

Studio W/B Mode

lets you set the color temperature to best match the applications in broadcast stations and studios.

Studio Gain Mode

increases the contrast to eliminate whiteout.

Screen Saver Functions

A variety of screen saver functions help lower the risk of uneven phosphor aging. The timer can also be used to set the screen saver operating time.

NANODRIFT SAVER	Moves the image smoothly.
OVERLAY SCROLLING BAR	The image brightness will be decreased and a white bar will scroll over it.
SCROLLING BAR ONLY	A white bar will scroll from left to right. The image will not be displayed.
NEGATIVE IMAGE	A negative image will be displayed on the screen.
SIDE PANEL ADJUSTMENT	Brightens the black bands on the sides of the screen while displaying images in a 4:3 format.
PEAK LIMIT MODE	Lowers the peak brightness level (image contrast).
WHITE SCREEN:	White will be displayed on the full screen.

New Screen Saver NANODRIFT SAVER

The new NANODRIFT SAVER reduces image retention five times*1 more effectively than previous systems. By using smooth, fine image movement it minimizes the possibility of image retention, without blocking the view.

- *1: Compared to our "wobbling" screen saver.
- NANODRIFT is a trademark of Panasonic Corporation.



Weekly Command Timer

This function makes it easy to automate display operation so there's no need for an external scheduler. You can set a variety of operations — power on/off, image source selection, screen saver functions and more — to activate at specific times on specific days of the week.

* This function is not provided on the PD12 Series.



Remote System Monitoring

Panasonic pro plasma displays feature a monitor command that lets you check the signal from a distant location. In conventional systems, you had to install a monitoring camera to check the images displayed on an advertising display panel or digital signage system. This monitor command, on the other hand, lets you monitor images by simply connecting a PC via a serial cable.

Tamper-Resistant Settings

You can prevent operating errors in public places by making tamper-resistant settings in advance.

- **Maximum volume level:** Sets the maximum sound volume.
- **Button lock:** Restricts the button operations for the display.
- **Remote user level:** Restricts the key operations for the remote control.

Audio Input Select

The video and audio input can each be independently selected. This makes it possible to achieve flexible combinations of images and sounds.

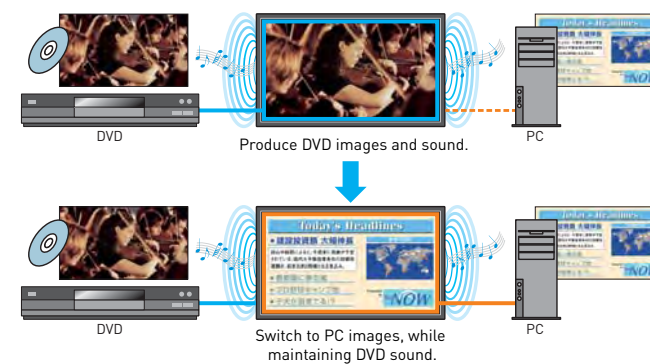

Automatic Picture Positioning

Simply press the Auto Setup key on the remote control to position the picture. This function automatically corrects horizontal and vertical picture positions, clock phase, and dot clock when an analogue RGB signal is selected as input. The adjustment results in optimal standard values for horizontal and vertical picture sizes.

- If the dot clock frequency is 162 MHz (for PF Series; 108 MHz for PH Series) or higher, DOT CLOCK and CLOCK PHASE cannot be made.
- When digital RGB signal input, DOT CLOCK and CLOCK PHASE cannot be made.



Auto Power Off

The Auto Power Off function automatically turns off the display power when the screen saver operation ends.

Extended Life Settings

It's easy to make settings that extend the display life because all items that prevent image retention are grouped into a single menu. There's also a menu that allows you to set the recommended values with a single operation.

Energy-Saving Functions

- **Power Management:** Power is automatically turned on or off in response to a sync signal from the equipment connected to the built-in DVI-D*2 or PC*3 input terminal.
- **Auto Power Off:** When you're using a device connected to the multi-function slots, the display panel goes into standby mode after about 10 minutes if no sync signal is received.
- **Power Save Mode:** Reduces the display's brightness.
- **Standby Power Save Mode:** Reduces power consumption when on standby.

- *2: Only PF20/PH20 Series
- *3: DPMS compliant

Included Remote Control Unit

TH-65PF12,
TH-58PF12,
TH-50PF20,
TH-42PF20

TH-50PH20
TH-42PH20

TH-103PF12,
TH-85PF12

A compact remote control unit with Auto Set Up function is included.

A 10-key remote control unit that supports Display ID Control is included.

List of Compatible Functions

Model	Network Function	Portrait Zoom	Multi Display	Blend Dual Picture	Dual Picture	Advanced Dual Picture	Digital Zoom	Picture Profiles	1:1 Pixel Mode	Monitor Mode	Display Size Setting	Studio W/B	Studio Gain	NANODRIFT SAVER	Screen Savers	Weekly Command Timer	Remote System Monitoring	Tamper-Resistant Setting	Audio Input Select	Automatic Picture Positioning	Auto Power Off	Extended Life Setting	Energy Saving Functions
TH-103PF12	*4																						
TH-85PF12	*4																						
TH-65PF12	*4																						
TH-58PF12	*4																						
TH-50PF20																							
TH-42PF20																							
TH-50PH20																							
TH-42PH20																							

• Compatible *4: Cannot be controlled by a web browser. *5: Not equipped with AUTO SET UP button.

New "Slot 2.0" Function Slot Expands Display Applications

PF20/PH20 Series

New "Slot 2.0" Function Slot



The new "Slot 2.0" function slot lets you add display functions to match the intended use. Mounting an optional function board allows the display to support a variety of applications.

Versatile Video Inputs with Multiple Digital, Analogue Connections

The PF20 and PH20 Series are equipped with full range of video input terminals, so you can input both analogue (Component Video, Video, PC) and digital (DVI-D, HDMI) video signals to the display. These standard-equipped terminals handle most of the commonly used video signals.

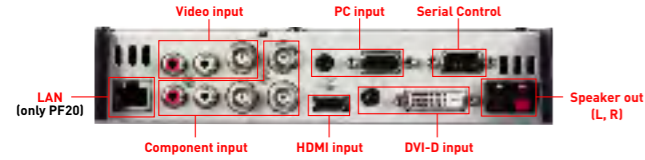

PF12 Series

Multi-Function Slots Offer Outstanding Flexibility

In addition to the fixed input interface, the PF12 Series models have three interchangeable slots that permit you add different combinations of optional terminal boards. This gives you the flexibility to add digital or analogue capabilities and customize your system.



Optional Terminal Boards

BNC Dual Video
TY-FB9BD

- S-Video and Composite (BNC)
- 2 x Audio L/R (RCA)

SLOT 2.0 Slot 1 Slot 2

DVI-D
TY-FB11DD

- DVI-D IN
- Audio L/R (M3 jack)

SLOT 2.0 Slot 1 Slot 2

Dual HDMI
TY-FB10HMD

- 2 x HDMI IN

SLOT 2.0 Slot 1 Slot 2

HD-SDI with Audio
TY-FB10HD

- HD-SDI video/audio input and output (BNC)

SLOT 2.0 Slot 1 Slot 2

Ir Through
TY-FB9RT

- 3 x IR-signal OUT (M3 jack)

SLOT 2.0 Slot 1 Slot 2 Slot 3

BNC Component Video
TY-42TM6A

- RGB/component video (BNC)
- Audio L/R (RCA)

Slot 1 Slot 2 Slot 3

RCA Component Video
TY-42TM6Z

- RGB/component video (RCA)
- Audio L/R (RCA)

Slot 1 Slot 2 Slot 3

BNC Composite Video
TY-42TM6B

- S-Video or Composite in/out (BNC)
- Audio L/R (RCA)

Slot 1 Slot 2

RCA Composite Video
TY-42TM6V

- S-Video or Composite in/out (RCA)
- Audio L/R (RCA)

Slot 1 Slot 2

PC Input
TY-42TM6P

- RGB (HV)/component video (D-Sub 15-pin)
- Audio L/R (M3 jack)

Slot 1 Slot 2 Slot 3

HDMI
TY-FB8HM

- HDMI IN

Slot 1 Slot 2

SDI
TY-FB7SD

- SD-SDI input and output (BNC)

Slot 1 Slot 2

HD-SDI
TY-FB9HD

- HD-SDI input and output (BNC)

Slot 1 Slot 2

SCART
TY-FB8SC

- RGB/S-Video/Composite (SCART 21-pin)
- Audio L/R (SCART 21-pin)

Slot 1 Slot 2

Composite/Component Video
TY-42TM6Y

- RGB (HV)/component video (BNC)
- S-Video or Composite in/out (BNC)
- 2 x Audio L/R (RCA)

Slot 1 & 2 Slot 2 & 3

RGB Active Through
TY-42TM6G

- RGB (HV)/component video (D-Sub HD 15-pin)
- RS-232C (D-Sub 9-pin)

Slot 1 & 2

DVB-T Digital Tuner
TY-FB11DTA

- HDMI IN
- Digital audio out
- Video out (RCA)
- Audio out (M3 jack)
- Ir system or through out
- SD Card Slot (used for servicing)

SLOT 2.0 Slot 2 & 3

U/V Tuner Board
TY-FB8TA

- Hospitality port
- Composite in/out
- S-video
- Audio in/out(L/R)
- IR out

SLOT 2.0 Slot 2 & 3

DMB-T/PAL Tuner Board
TY-FB12DTH

- HDMI IN
- Audio out
- SD Card Slot (used for servicing)

SLOT 2.0 Slot 2 & 3

Dual Link HD-SDI Board

TY-FB11DHD



- Supports the high-resolution, high-quality Dual Link HD-SDI (in compliance with SMPTE372M) and the HD-SDI (in compliance with SMPTE292M) used in broadcasting.
- Allows direct input of 2K digital cinema signals* in compliance with DCI (Digital Cinema Initiatives) without using a converter.
- Compatible with RGB 4:4:4/YPbPr 4:2:2@60p, 50p/2K digital cinema signals in compliance with DCI.
- Provides simultaneous video and embedded audio (max. 16 channels)* signal transmission using a single cable.

Max Transmission Distance/Recommended Cable

100 m*/75-ohm coaxial cable 5C-FB
* When using a cable with less than 20dB/100 m (750 MHz)

Compatible Video Signal

Signal format	Sampling structure/Number of pixel bits	SDI name
750 (720)/40p: 59.94p	YCbCr (4:2:2)/10-bit	HD-SDI
750 (720)/50p		
1,125 (1,080)/40i: 59.94i		
1,125 (1,080)/50i		
1,125 (1,080)/30p: 29.97p		
1,125 (1,080)/25p		
1,125 (1,080)/24p: 23.985p	RGB (4:4:4), RGB + A (4:4:4:4)/10-bit YCbCr (4:4:4), YCbCr + A (4:4:4:4)/10-bit RGB (4:4:4), YCbCr (4:2:2), YCbCr (4:4:4)/12-bit ²	Dual-Link HD-SDI
1,125 (1,080)/24sf: 23.985sf		
1,125 (1,080)/40i: 59.94i		
1,125 (1,080)/50i		
1,125 (1,080)/30p: 29.97p		
1,125 (1,080)/25p		
1,125 (1,080)/24p: 23.985p	YCbCr (4:2:2)/10-bit	Dual-Link HD-SDI
1,125 (1,080)/24sf: 23.985sf		
1,125 (1,080)/50p	RGB (4:4:4), X'Y'Z' (4:4:4)/12-bit ²	Dual-Link HD-SDI
2,048 x 1,080/24p: 23.985p		
2,048 x 1,080/24sf: 23.985sf		

*1: A (Alpha channel) is not supported. This data cannot be output.
*2: A 12-bit signal can be received, but it will be converted to a 10-bit signal for the display of images.

Wireless Presentation Board

TY-FB10WPE



Wireless Card (A protective cover is included for wireless card use.)

- Wireless connection (IEEE 802.11b/11g) eliminates the need to connect any cables between the display and a PC.
- High-speed wireless transmission produces smooth-motion images.
- Images from one PC can be displayed in real-time on as many as eight displays simultaneously.
- Images from up to 16 PCs can be simultaneously displayed onto a single screen.
- Plasma displays can be controlled using a Web browser.



Up to four PCs can be used.

- Wireless card
- RGB/component video (RCA)
- Audio L/R (RCA)

Note
• Normal operation may not be possible when the board is combined with another application (such as an image rotating utility) using the image data.
• This board cannot be used in some countries.

System Configuration Required by Wireless Manager software

	Windows	Macintosh*
OS	Microsoft Windows 2000 Professional/XP Home Edition/XP Professional Microsoft Windows Vista™ Ultimate 32 bit*/Vista™ Business 32 bit* Microsoft Windows Vista™ Home Premium 32 bit*/Vista™ Home Basic 32 bit*	Mac OS X v10.4 Mac OS X v10.5*
CPU	Intel Pentium III 600 MHz or faster (or compatible processor) (Processing speed of 800 MHz or faster recommended for Live mode)	Power PC G4 800 MHz or faster, or Intel Core processor 1.8 GHz or faster
Memory	256 MB or more	256 MB or more (Recommended 512MB or more)
HDD	60 MB or more of available disk space	60 MB or more of available disk space
Required hardware	<ul style="list-style-type: none"> CD or DVD drive (for installing software and browsing the instruction manual) LAN terminal (10BASE-T/100BASE-TX/1000BASE-T) A correctly operating wireless LAN function supporting IEEE 802.11b/g, however, there are some cases where the device does not receive 802.11g signal, though the wireless LAN supports 802.11b/g 	
Web browser	Microsoft Internet Explorer 6.0 or newer Netscape Communicator 7.0 or newer	Safari 2.0 or newer

*1: Only supported by Wireless Manager ME4.5.
*2: The device can only used with Intel MacBook or MacBook Pro equipped with Core 2 Duo processor.
Note: • Usable functions are limited when operating under Windows Vista or MAC OS.
• Microsoft, Windows and PowerPoint are either trademarks or registered trademarks of Microsoft Corporation in the United States and/or other countries.
• Intel and Pentium are either trademarks or registered trademarks of Intel Corporation in the United States and/or other countries.
• Visit the website for more details on wireless manager software. <http://panasonic.net/proplasma>

List of Compatible Terminal Boards

	TY-FB9BD	TY-FB11DD	TY-FB10HMD	TY-FB10HD	TY-FB9RT	TY-42TM6A	TY-42TM6Z	TY-42TM6B	TY-42TM6V	TY-42TM6P	TY-FB8HM	TY-FB7SD	TY-FB9HD	TY-FB8SC	TY-42TM6Y	TY-42TM6G	TY-FB11DTA	TY-FB8TA	TY-FB12DTH	TY-FB11DHD	XTX series	MPL3222
TH-103PF12	●	●	●	●	●	●	●	●	●	●	●	●	●	●	●	●	●	●	●	●	●	●
TH-85PF12	●	●	●	●	●	●	●	●	●	●	●	●	●	●	●	●	●	●	●	●	●	●
TH-65PF12	●	●	●	●	●	●	●	●	●	●	●	●	●	●	●	●	●	●	●	●	●	●
TH-58PF12	●	●	●	●	●	●	●	●	●	●	●	●	●	●	●	●	●	●	●	●	●	●
TH-50PF20	●	●	●	●	●	●	●	●	●	●	●	●	●	●	●	●	●	●	●	●	●	●
TH-42PF20	●	●	●	●	●	●	●	●	●	●	●	●	●	●	●	●	●	●	●	●	●	●
TH-50PH20	●	●	●	●	●	●	●	●	●	●	●	●	●	●	●	●	●	●	●	●	●	●
TH-42PH20	●	●	●	●	●	●	●	●	●	●	●	●	●	●	●	●	●	●	●	●	●	●

AV Terminal Box

TY-TB10AV



- Ideal for hotel guest rooms. Two input terminals (VIDEO/RGB) allow guests to easily connect to their own laptop PC, DVD player, or other portable device.
- The TY-TB10AV can also be built into a desk or a bed sideboard.

Peripherals

PDP Controller

XTX-1312 series **SLOT 2.0** Slot 1 & 2 Slot 2 & 3

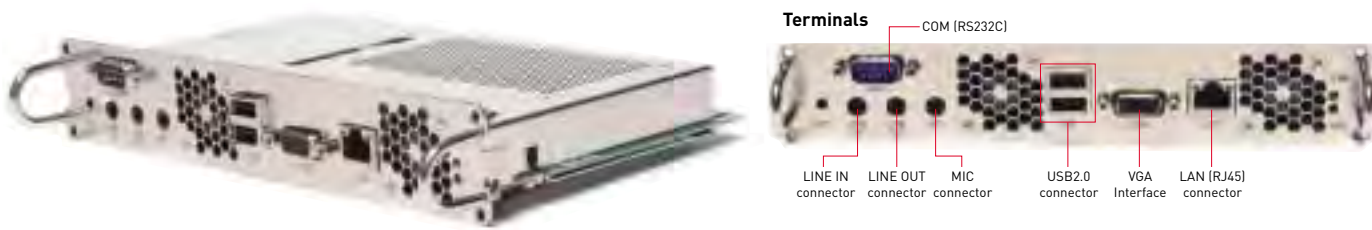

These high-performance internal PCs can be easily installed in the displays and offer the advantage of an all-in-one solution.

- Compact 2-slot width plug-in PC to facilitate turn-key solutions.
- Invisible installation, power supply through the display.
- Supports Compact Flash Cards.
- Supports VGA output for additional display.

*The PDP Controller cannot be combined for use with other terminal boards.
**This board is not available in some countries.

System Example

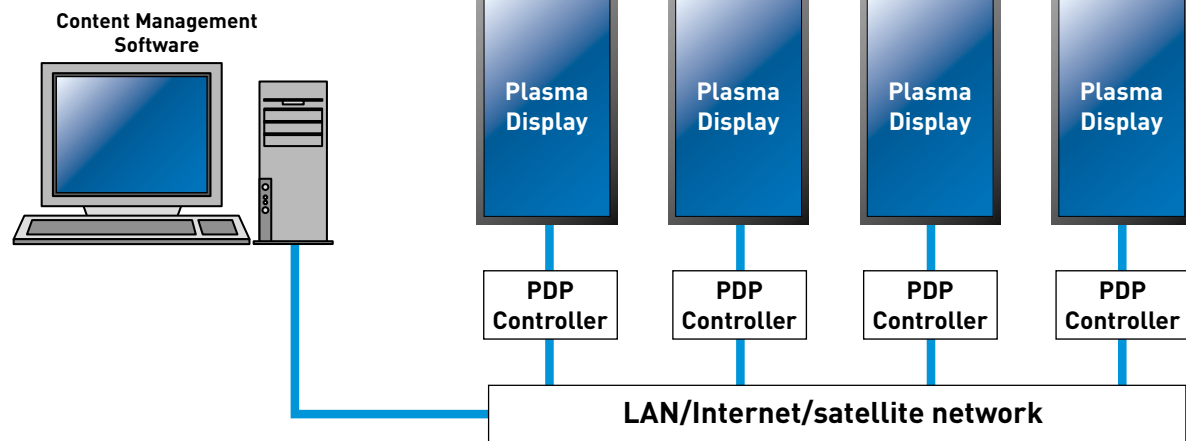

Specifications

Model number	XTX1312-U2500	XTX1312-C423	XTX1312-N270BC	XTX1312-N270	XTX1312-U2500-XPE	XTX1312-C423-XPE	XTX1312-N270BC-XPE	XTX1312-N270-XPE
Processor	Intel Core Duo U2500 1.2 GHz	Intel Core Duo C423 1.06 GHz	Intel Single Core Atom N270 1.6 GHz	Intel Core Duo U2500 1.2 GHz	Intel Core Duo C423 1.06 GHz	Intel Single Core Atom N270 1.6 GHz	Intel Single Core Atom N270 1.6 GHz	Intel Single Core Atom N270 1.6 GHz
Memory	1GB RAM (DDR2 SO-DIMM)							
Internal HDD	80GB SATA HDD							
Interfaces	1 x LAN, 2 x USB2.0, 1 x Serial, 1 x Line In/Out, 1 x Mic in, 1 x VGA Out							
Pre-installed OS	-				Windows XP embedded			
Power supply	Supplied from the plasma display							
Standards	FCC, CE, RoHS							

Media Player

MPL3222 **SLOT 2.0**



Terminals

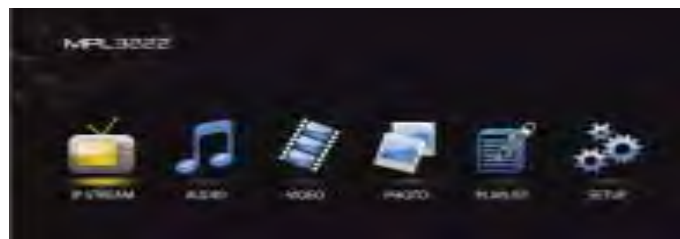

- Playback Video / Music / Photo Slideshow from SDHC Card, USB Devices, or shared media Files from other PCs over the network as well as IP Multicast HD Streams.
- Also have feature of Popup Banner & Marquee Text Signage. Easy field programmable Digital Signage for effective Signage Application.

*This board is not available in some countries.

Specifications

Interface	SDHC card slot x1, USB 2.0 port x2 (Type-A Host Connector), LAN(RJ45) x1
Supported Video Format	Mpeg-1, Mpeg-2, Mpeg-2 TS, Mpeg-4.10 (H.264), WMV9 (HD), AVCHD, MOV (Apple), Xvid
Supported Audio Format	MP3, WMA and WAV
Supported Picture Format	JPEG, BMP, GIF, PNG
Picture Resolution	Up to 2048*1532
OSD Language	English

Touch Panel



Touch Panel (CMOS Camera Detection System)

- TY-TP65P10S (for 65-inch model)
- TY-TP58P10S (for 58-inch model)
- TY-TP50P10S (for 50-inch model)
- TY-TP42P10S (for 42-inch model)

- Two infrared image sensors detect coordinates based on a triangulation method.
- High resolution and smooth operation.
- Dividable frame system for compact packaging.

Note: The touch panel does not include a drawing application. You cannot mount both a TY-TP65P10S or TP58P10S Touch Panel and an Anti-Glare Filter at the same time. Do not use the touch panel near windows or other locations where external light is directly reflected, or operating errors may result.

Examples of Touch-Panel Solutions



Discussion Display Panel
Information can be handwritten directly onto the sharp, clear images of the plasma display. This lets you visually summarise people's opinions and comments right on the screen for more efficient meetings.



Information Display Panel
A display system can be configured that lets the user flexibly retrieve information. An intuitive interface enables easy operation by simply touching the screen, making the system ideal for use in public facilities and commercial complexes.

Specifications

Model Number	TY-TP42P10S	TY-TP50P10S	TY-TP58P10S	TY-TP65P10S
Power source	Voltage			
	+ 5 V DC ± 10%			
	Electric current			
Max. 450 mA				
Supply system				
From USB bus				
Touch panel	Detection system			
	Infrared retroreflective detection			
	Panel window (W x H)			
	938 x 535 mm	1,128 x 648 mm	1,305 x 747.5 mm	1,449 x 819 mm
	Detection range (W x H)			
	920 x 518 mm	1,106 x 622 mm	1,287 x 723.5 mm	1,434 x 807 mm
	Effective detection range			
	Same as above	Same as above	Same as above	Same as above
	Resolution			
	Approx. 32,000 [W] x 18,000 [H] points ^{*1}			
Output system				
Coordinate output				
Optic elements				
Infrared LED x 4, CMOS image sensor x 2				
Minimum detection size				
7 mm	8 mm	9 mm	10 mm	
Response rate				
100 points/sec				
Interface	USB 2.0 full speed device			
	Signals: +DATA, -DATA, VCC, GND			
	Connector: Type B			
Resistance to external light	Lateral light: 2,000 lx + 20% (20° angle of incidence)			
	Frontal light: 10,000 lx + 20% (90° angle of incidence)			
	External dimensions (W x H x D)			
1,016.4 x 686 x 47.9 mm	1,206.4 x 798.6 x 47.9 mm	1,395.4 x 923.1 x 47.9 mm	1,550.8 x 1,008.2 x 47.9 mm	
Mass				
Approx. 4.1 kg	Approx. 4.6 kg	Approx. 5.8 kg	Approx. 6.7 kg	
Escutcheon material				
Aluminum				
Applicable OS				
Microsoft® Windows® 2000, Windows® XP, Windows® Vista (32 bit)				

*1: Resolution obtained by using a dedicated Driver software.

Anti-Glare Filter

- TY-AR65P9W (for 65-inch model)
- TY-AR58P10W (for 58-inch model)
- TY-AR50P12W (for 50-inch model)
- TY-AR42P12W (for 42-inch model)



Without Anti-Glare Filter



With Anti-Glare Filter

- Mounting this filter to the front of the plasma display reduces glare from external light sources and reflections from fluorescent lighting.
- Anti-glare filter suppresses the transmission of visible light rays and improves contrast, to provide sharp, crisp images.
- This filter also has excellent physical characteristics, for preventing static electricity and resisting surface abrasion (with a surface hardness of 2H).

An Endless Array of Applications

EDUCATION

National University of Singapore Singapore 2 x 103"

The previous projector system in the lecture room was replaced by these plasma displays. By solving problems such as the instructor's shadow covering the screen thereby making it difficult to see the images projected, and not being able to see images clearly unless shown in a dark room, these new displays offer excellent clarity and flexibility, even in brightly lit rooms.



DIGITAL SIGNAGE

Raymour & Flanigan USA

The material in the fine furniture and fabrics that are exhibited at Raymour & Flanigan stores are displayed in highly realistic large-screen images. The 85-inch plasma display, which features a wide viewing angle and excellent clarity, displays consistently sharp, easy-to-see information.

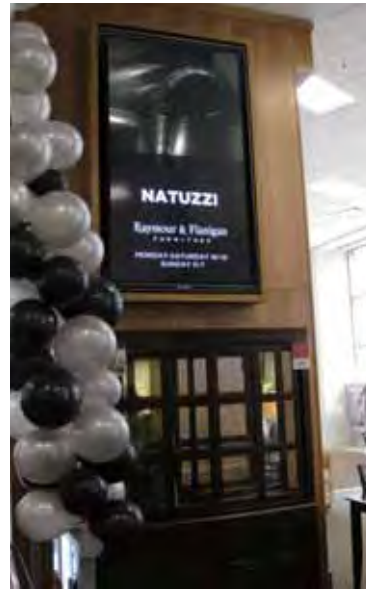
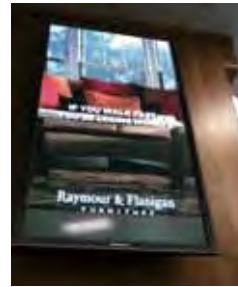

ENTERTAINMENT

IGT USA

IGT is the world's largest game machine manufacturer and holds the largest share of the slot machine market. IGT has integrated the 103" plasma display in some of its newest systems so a group of people can experience the gaming excitement at the same time.



LEISURE

Paradis du Fruit Paris, France 13 x 103"

Paradis du Fruit is a restaurant chain in France. As part of a renovation project, thirteen Panasonic 103-inch plasma displays have been installed in its flagship restaurant in Paris. The high-quality images of these large screens form an integral part of a design concept that was created by Philippe Starck, a renowned spatial designer. The displays also complement the fresh, modern look of the restaurant's interior. Their impact is sure to remain in each customer's memory for years to come.



West Ashfield Leagues Club Australia

Several 103-inch plasma displays are installed at the spectator seats, game floor, and restaurant of the West Ashfield Leagues Club. Panasonic plasma displays can be individually configured and mounted either horizontally or vertically, they were ideally suited to meet the Club's special needs.



Cinépolis Latin America

With Panasonic, Cinépolis — the largest movie theater company in Latin America — found a business partner capable of delivering solutions tailored to their specific needs. In addition to the endurance and robustness of all Panasonic plasma displays, these plasma panels also offer quality images and a wide variety of functions for ease of operation. During their five-year partnership Cinépolis and Panasonic has installed more than 3,000 plasma displays at Cinépolis' theaters, averaging 15 screens at each complex.



MEDICAL CARE

Ehime University Hospital Ehime, Japan 12 x 50", 3 x 37"

Plasma displays with superb colour reproduction, uniform colouring, and high-speed image response were installed in their operating rooms. The 50-inch displays are currently being used as observation monitors for medical students to view important surgical procedures.



Nagoya Daini Red Cross Hospital Nagoya, Japan

This hospital recently changed its system of calling patients for examinations by their individual names. Instead, the hospital now uses patient numbers and an audio system aided by video animation that's shown on a plasma display. This better protects the privacy of the patients, and the high contrast and wide viewing angle makes the displayed images clearly visible from any location within the waiting room.



TV PRODUCTION

KHOU TV Houston, USA 3 x 50", 9 x 42", 3 x 58", 2 x 37"

Panasonic plasma displays reproduce colours across the entire HDTV-standard range, so colours are faithful and natural-looking. Superior motion-image resolution reproduces fast-action images with stunning clarity. The slim design allows considerable installation flexibility for creating a neat, attractive studio design.



Specifications



TH-103PF12W (Anti-Glare, Low-Reflection model)
103-inch (260 cm) diagonal
Full High Definition Plasma Display



TH-85PF12W (Anti-Glare, Low-Reflection model)
85-inch (217 cm) diagonal
Full High Definition Plasma Display

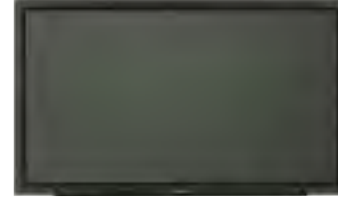

TH-65PF12WK
65-inch (164 cm) diagonal
Full High Definition Plasma Display



TH-58PF12WK
58-inch (147 cm) diagonal
Full High Definition Plasma Display



TH-50PF20W
50-inch (126 cm) diagonal
Full High Definition Plasma Display



TH-42PF20W
42-inch (105 cm) diagonal
Full High Definition Plasma Display

Specifications

	TH-103PF12W	TH-85PF12W	TH-65PF12WK	
DISPLAY	Screen Size [Diagonal]	103-inch	85-inch	65-inch
	Aspect Ratio	16:9	16:9	16:9
	Effective Display Area [W x H]	2,269 x 1,276 mm	1,889 x 1,062 mm	1,434 x 806 mm
	Number of Pixels [H x V]	1,920 x 1,080 pixels	1,920 x 1,080 pixels	1,920 x 1,080 pixels
	Pixel Pitch [H x V]	1.182 x 1.182 mm	0.984 x 0.984 mm	0.747 x 0.747 mm
	Contrast Ratio	40,000:1	40,000:1	40,000:1
	Gradation	6,144 steps (equivalent)	6,144 steps (equivalent)	6,144 steps (equivalent)
SIGNAL COMPATIBILITY	Moving Picture Resolution	1,080 lines	1,080 lines	1,080 lines
	Scanning Frequency	Horizontal : 15 — 110 kHz / Vertical : 48 — 120 Hz		
INPUT	PC Signal Compatibility	VGA, SVGA, XGA, WXGA, SXGA, UXGA [Over SXGA resolution: compressed]		
	Video Signal Compatibility	525 (480)/60i, 60p; 625 (575)/50i, 50p; 625 (576)/50p; 750 (720)/60p, 50p; 1125 (1080)/60i, 50i, 24p, 24sF, 25p, 30p, 60p, 50p; 1250 (1080)/50i		
CONTROL	COMPONENT/RGB IN	BNC x 3 (on Function Board)		
	AUDIO IN (for COMPONENT)	M3 x 1 (on Function Board)		
	HDMI IN	HDMI x 2 (on Function Board)		
SOUND	PC IN	Mini D-sub 15-pin x 1		
	AUDIO IN (for PC)	M3 x 1		
ELECTRICAL	RS-232C	D-sub 9-pin x 1		
	LAN	RJ45: 10BASE-T/100BASE-TX, PLink™ compatible (on Function Board)		
MECHANICAL	Audio Output	RCA (L/R) x 1 set, Output level: variable (-∞ to 0 dB at 10 kilohms)		
	Power Requirements	220 - 240 V AC, 50 Hz/60 Hz	220 - 240 V AC, 50 Hz/60 Hz	220 - 240 V AC, 50 Hz/60 Hz
	Power Consumption	1,400 W	1,200 W	695 W
	On Mode Average Power Consumption ²	1,065 W	890 W	570 W
OPERATION	Power off Condition	0.4 W	0.4 W	0.4 W
	Stand-by Condition	Save Off: 1.2 W, Save On: 0.7 W	Save Off: 1.2 W, Save On: 0.7 W	Save Off: 1.2 W, Save On: 0.7 W
	Dimensions [W x H x D]	2,412 x 1,419 x 129 ¹ mm	2,015 x 1,195 x 99 mm	1,554 x 925 x 99 mm
	Weight (approx.)	201.0 kg	117.0 kg	59.0 kg
OPERATION	Function Slot (Vacant)	3 (1)	3 (1)	3 (1)
	Temperature	0°C — 40°C		
	Humidity	20% — 80% (Non condensation)		
	Altitude	0 — 2,400 m		
OPERATION	Radiation Regulations	CISPR22 Class-B, NOM approval		
	Safety Standards	AS/NZS60065, SASO, IEC60065/SS (Singapore), IEC60065/PAI, IEC60065, GOST12.2.006-87, IEC60065/NOM approval		

*1: Exclusive of protruding portion [141 mm when including the protruding portion of the slot]

*2: Based on IEC 62087 Ed. 2 measurement method.

TH-103PF12W

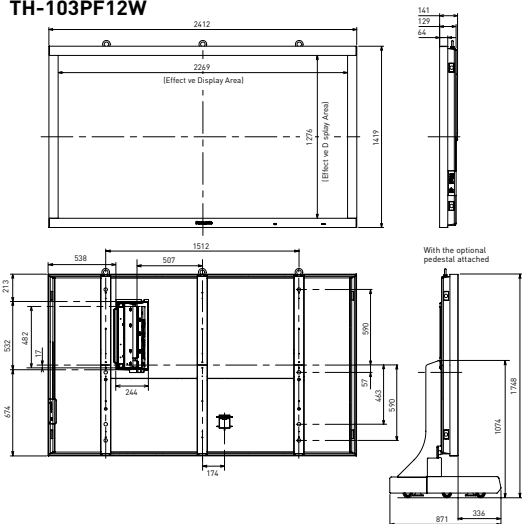

TH-85PF12W

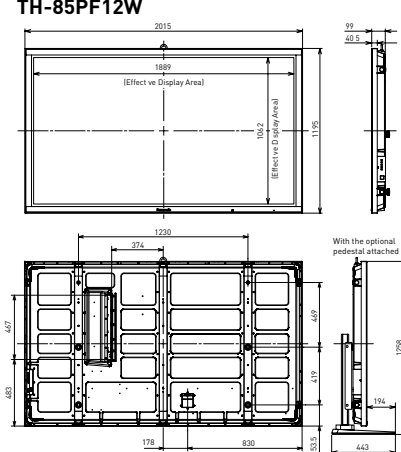

TH-65PF12WK

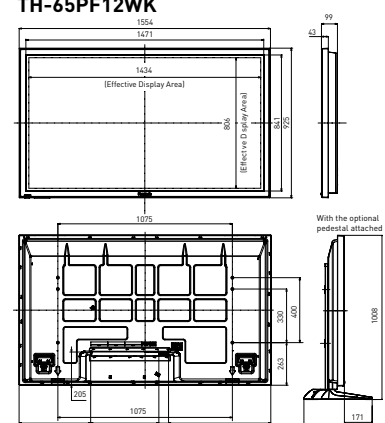

[Unit: mm]

Specifications

	TH-58PF12WK	TH-50PF20W	TH-42PF20W	
DISPLAY	Screen Size [Diagonal]	58-inch	50-inch	42-inch
	Aspect Ratio	16:9	16:9	16:9
	Effective Display Area [W x H]	1,284 x 722 mm	1,105 x 622 mm	921 x 518 mm
	Number of Pixels [H x V]	1,920 x 1,080 pixels	1,920 x 1,080 pixels	1,920 x 1,080 pixels
	Pixel Pitch [H x V]	0.669 x 0.669 mm	0.576 x 0.576 mm	0.480 x 0.480 mm
	Contrast Ratio	40,000:1	5,000,000:1 ^{*1}	5,000,000:1 ^{*1}
	Gradation	6,144 steps (equivalent)	6,144 steps (equivalent)	6,144 steps (equivalent)
SIGNAL COMPATIBILITY	Moving Picture Resolution	1,080 lines	1,080 lines	1,080 lines
	Scanning Frequency	Horizontal : 15 — 110 kHz / Vertical : 48 — 120 Hz		
INPUT	PC Signal Compatibility	VGA, SVGA, XGA, WXGA, SXGA, UXGA [Over SXGA resolution: compressed]		
	Video Signal Compatibility	525 (480)/60i, 60p; 625 (575)/50i, 50p; 625 (576)/50p; 750 (720)/60p, 50p; 1125 (1080)/60i, 50i, 24p, 24sF, 25p, 30p, 60p, 50p; 1250 (1080)/50i		
CONTROL	COMPONENT/RGB IN	BNC x 3		
	AUDIO IN (for VIDEO)	RCA (L/R) x 1 set		
	AUDIO IN (for COMPONENT)	RCA (L/R) x 1 set		
SOUND	HDMI IN	HDMI x 1		
	DVI-D IN	DVI-D x 1		
ELECTRICAL	AUDIO IN (for DVI-D)	M3 x 1		
	PC IN	Mini D-sub 15-pin x 1		
MECHANICAL	AUDIO IN (for PC)	M3 x 1		
	RS-232C	D-sub 9-pin x 1		
OPERATION	LAN	RJ45: 10BASE-T/100BASE-TX, PLink™ compatible (on Function Board)		
	Audio Output	16 W [8 W + 8 W] [10 % THD]	16 W [8 W + 8 W] [10 % THD]	16 W [8 W + 8 W] [10 % THD]
	Power Requirements	220 - 240 V AC, 50 Hz/60 Hz	220 - 240 V AC, 50 Hz/60 Hz	220 - 240 V AC, 50 Hz/60 Hz
	Power Consumption	660 W	445 W	375 W
OPERATION	On Mode Average Power Consumption ²	500 W	370 W	300 W
	Power off Condition	0.4 W	0.3 W	0.3 W
	Stand-by Condition	Save Off: 1.2 W, Save On: 0.7 W	Save Off: 1.1 W, Save On: 0.6 W	Save Off: 1.1 W, Save On: 0.6 W
	Dimensions [W x H x D]	1,399 x 843 x 99 mm	1,210 x 724 x 89 mm	1,020 x 610 x 89 mm
OPERATION	Weight (approx.)	48.0 kg	31.0 kg	24.0 kg
	Function Slot (Vacant)	3 (1)	1 (1: SLOT2.0)	1 (1: SLOT2.0)
OPERATION	Temperature	0°C — 40°C		
	Humidity	20% — 80% (Non condensation)		
	Altitude	0 — 2,800 m		
	Radiation Regulations	CISPR22 Class-B		
OPERATION	Safety Standards	AS/NZS60065, SASO, IEC60065/SS (Singapore), IEC60065/PAI, IEC60065		

*1: The dark room contrast ratio of the panel unit that can be displayed simultaneously on the same screen. Measured in "Dynamic" picture mode using a white signal in a 4% window.

*2: Based on IEC 62087 Ed. 2 measurement method.

TH-58PF12WK

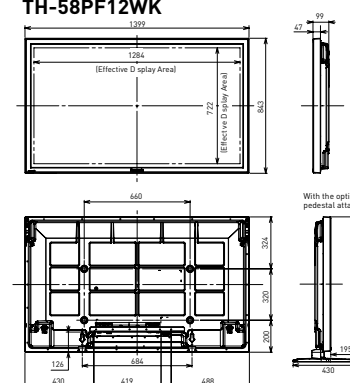

TH-50PF20W

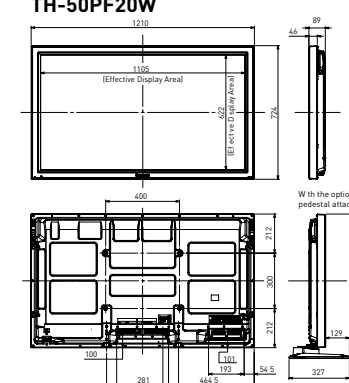

TH-42PF20W

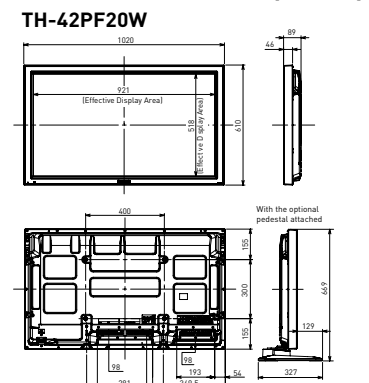

[Unit: mm]

Specifications



TH-50PH20W
50-inch (126 cm) diagonal
High Definition Plasma Display



TH-42PH20W
42-inch (105 cm) diagonal
High Definition Plasma Display

Specifications

	TH-50PH20W	TH-42PH20W	
DISPLAY	Screen Size (Diagonal)	50-inch	42-inch
	Aspect Ratio	16:9	16:9
	Effective Display Area (W x H)	1,105 x 622 mm	921 x 518 mm
	Number of Pixels (H x V)	1,024 x 768 pixels	1,024 x 768 pixels
	Pixel Pitch (H x V)	1.080 x 0.810 mm	0.900 x 0.675 mm
SIGNAL COMPATIBILITY	Contrast Ratio	2,000,000:1*	2,000,000:1*
	Gradation	5,120 steps (equivalent)	5,120 steps (equivalent)
	Moving Picture Resolution	720 lines	720 lines
	Scanning Frequency	Horizontal : 15 — 110 kHz / Vertical : 48 — 120 Hz	
	PC Signal Compatibility	VGA, SVGA, XGA, WXGA, SXGA, UXGA (Over XGA resolution: compressed)	
INPUT	Video Signal Compatibility	525 (480/60i, 60p; 625 (575/50i, 50p; 625 (576/50p; 750 (720/60p, 50p; 1125 (1080/60i, 50i, 24p, 24sF, 25p, 30p, 60p, 50p; 1250 (1080/50i	
	VIDEO IN	BNC x 1	BNC x 1
	AUDIO IN (for VIDEO)	RCA (L/R) x 1 set	RCA (L/R) x 1 set
	COMPONENT/RGB IN	BNC x 3	BNC x 3
	AUDIO IN (for COMPONENT)	RCA (L/R) x 1 set	RCA (L/R) x 1 set
	HDMI IN	HDMI x 1	HDMI x 1
	DVI-D IN	DVI-D x 1	DVI-D x 1
	AUDIO IN (for DVI-D)	M3 x 1	M3 x 1
	PC IN	Mini D-sub 15-pin x 1	Mini D-sub 15-pin x 1
	AUDIO IN (for PC)	M3 x 1	M3 x 1
CONTROL SOUND	RS-232C	D-sub 9-pin x 1	
	Audio Output	16 W [8 W + 8 W] [10 % THD]	
	Power Requirements	220 - 240 V AC, 50 Hz/60 Hz	
ELECTRICAL	Power Consumption	330 W	275 W
	On Mode Average Power Consumption ²	245 W	190 W
	Power off Condition	0.3 W	0.3 W
	Stand-by Condition	Save Off: 1.1 W, Save On: 0.6 W	Save Off: 1.1 W, Save On: 0.6 W
MECHANICAL	Dimensions (W x H x D)	1,210 x 724 x 89 mm	1,020 x 610 x 89 mm
	Weight (approx.)	33.0 kg	25.0 kg
OPERATION	Function Slot (Vacant)	1 [1: SLOT2.0]	1 [1: SLOT2.0]
	Temperature	0°C — 40°C	
	Humidity	20% — 80% (Non condensation)	
	Altitude	0 — 2,800 m	
Radiation Regulations			CISPR22 Class-B
Safety Standards			AS/NZS60065, SASO, IEC60065/SS (Singapore), IEC60065/PAI, IEC60065

*1: The dark room contrast ratio of the panel unit that can be displayed simultaneously on the same screen. Measured in "Dynamic" picture mode using a white signal in a 4% window.

*2: Based on IEC 62087 Ed. 2 measurement method.

TH-50PH20W

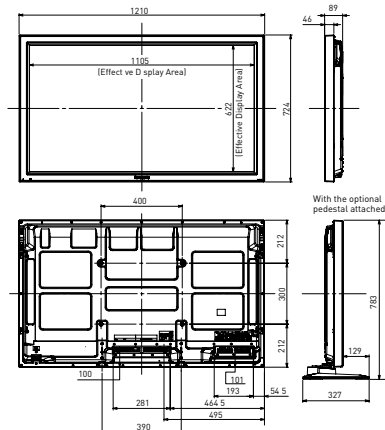

TH-42PH20W

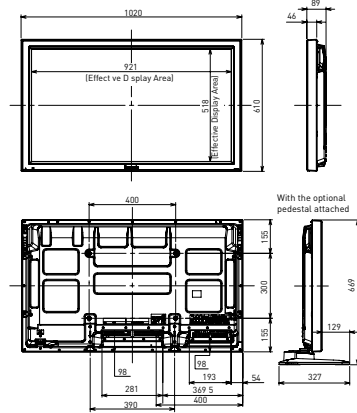

[Unit: mm]

Mounting Options

Pedestal

TY-ST103PF9
Weight: 122.0 kg



TY-ST85P12
Weight: 58.0 kg



TY-ST65P11-K
Weight: 17.0 kg



TY-ST58-K
Weight: 3.4 kg



TY-ST20-K
Weight: 7.0 kg



Wall-hanging bracket * Also usable for vertical mounting.

TY-WK103PV9
Weight: 25.0 kg



TY-WK85PV12
Weight: 18.0 kg



TY-WK65PV7
Weight: 8.3 kg



TY-WK42PV7
Weight: 3.0 kg

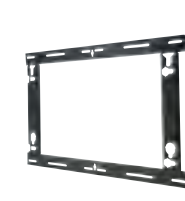

TY-WK42PV20
Weight: 2.3 kg



Wall-hanging bracket (angled)

TY-WK65PR8
Weight: 12.0 kg



TY-WK42PR7
Weight: 5.2 kg

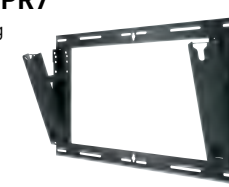

TY-WK42PR20
Weight: 3.2 kg



Ceiling-hanging bracket

TY-CE103PS10 Adjustable angle: 0° — 20°
Weight:
Vertical type: 15.0 kg
Inclined type: 37.0 kg



The photo shows the bracket at 20° incline.

TY-CE85PS12 Adjustable angle: 0° — 20°
Weight: 35.0 kg

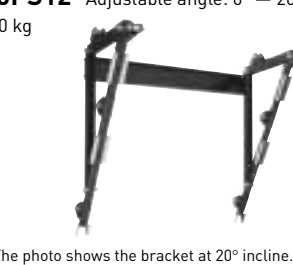

The photo shows the bracket at 20° incline.

TY-CE42PS20
Weight: 16.0 kg



Floor stand

TY-ST85PF12
Weight: 82.0 kg



Mobile stand

TY-ST58PF10
Weight: 32.0 kg



TY-ST58PF20
Weight: 33.0 kg



* To prevent overturning when using the floor stand, mount the stand brace to the wall. This will halt any vibration. The casters are not to be used for moving the main unit around.

Detachable stereo speakers

TY-SP65P11WK (for 65-inch)
Weight: 2.2 kg/each
TY-SP58P10WK (for 58-inch)
Weight: 2.5 kg/each
TY-SP50P8W-K (for 50-inch)
Weight: 2.0 kg/each
TY-SP42P8W-K (for 42-inch)
Weight: 2.0 kg/each

