

SONY®

Data Projectors

VPL-FX52 VPL-FX52L



Astonishing Brightness of 6000 ANSI Lumens in a Stylish Body – Make the Sony VPL-FX52 Data Projector Your Choice!

Delivering a high-brightness output of 6000 ANSI lumens in a stylish body, the VPL-FX52 is an excellent choice for high-impact multimedia presentations. For any number of applications ranging from business conferences and seminars to education, in locations such as auditoriums, large conference rooms and lecture halls, the VPL-FX52 will captivate audiences with breathtaking image quality.*

Seen from any angle, this beautifully designed projector brings an elegant and stylish addition to any display environment. Its outstanding functionality – including the ability to project high-quality images, networking capability, and installation flexibility – gives you the power to show your presentations and image files with exceptional clarity. What's more, the projector's ability to accept almost any kind of signal makes presentations from a variety of sources much more feasible. And with the VPL-FX52L, you can choose a lens that meets your application requirements. With additional functionality including Smart APA (Auto Pixel Alignment), a Direct Power On feature, and user-friendly operation, the VPL-FX52 is an ideal projector for almost any large conference room or auditorium – make it your choice!

* ANSI lumen is a measuring method of the American National Standards Institute IT7.228. Since there is no uniform method of measuring brightness, specifications will vary among manufacturers.



FEATURES

Outstanding Brightness of 6000 ANSI Lumens

The Sony VPL-FX52 Data Projector achieves an outstanding brightness of 6000 ANSI lumens for dynamic, large-screen presentations. The high aperture ratio, 1.3-inch LCD panels, together with a Micro Lens Array, provides significant light-transmission efficiency. By combining this latest Sony LCD technology with a 300W lamp, high-impact images can be brought to life with stunning color fidelity.

3LCD Projection System

Because the VPL-FX52 adopts a 3LCD projection system, projected images are bright and natural. 3LCD is a projection system using three LCD panels (also known as high-temperature polysilicon or HTPS). This system provides high light transmission and excellent color reproduction. It also provides smooth gradients in dark areas, and even helps prevent color breakup.



Elegant Design

The VPL-FX52 not only projects beautiful images; its simple yet sophisticated design makes a statement even before it's turned on. The exhaust and connector panel are located on the front of the unit so that the projector will blend in smoothly with its installation environment. It has also been designed with symmetry in mind, with the centralized lens offering simple, balanced installation.



High Quality and Performance

Dynamic Detail Enhancer (DDE) For High-Quality Video Images

This unique Sony video-enhancing technology generates high-quality images of outstanding clarity. For video sources, I/P (Interlace/Progressive) conversion is applied to interlace signals to project clear and sharp progressive images. When displaying film-originated sources, signals converted by 2-3 pull down*1 are detected, and each frame of the original film is accurately reproduced. The VPL-FX52 projects images with a high degree of accuracy by adopting unique driver circuitry that enables it to accept digital signals directly.

*1 2-3 pull down is only available for 60-Hz signals (NTSC).

I/P Conversion

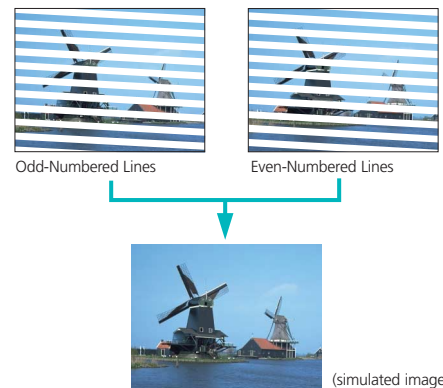

2-3 Pull Down

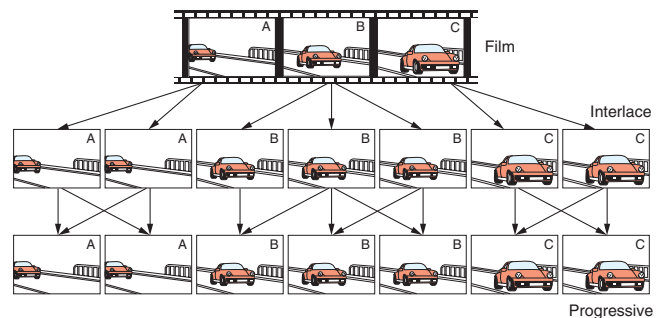

RGB Enhancer

The RGB Enhancer can be adjusted from the On-Screen Display (OSD), for enriched and crisp RGB image reproduction.

3D Gamma Correction

10-bit 3D Gamma Correction circuitry performs highly accurate gamma correction to give uniform image color and brightness that extends right to the corners of the screen.

3D Digital Comb Filter

Thanks to the Sony original 3D Digital Comb Filter that separates Y signals from C signals with great accuracy, it is easy to emphasize fine images and shape boundaries.

Installation Flexibility

Power Zoom/Focus/Picture Shift

The Zoom, Focus, and Picture Shift functions of the supplied power-operated lens^{*2} can be controlled both from the projector control panel and the supplied remote-control unit. Images can be easily adjusted to the desired settings.

^{*2} Available only on the lens supplied with the VPL-FX52.

Flexible Orientation

The VPL-FX52 can be tilted 90 degrees upwards or downwards. This flexibility greatly expands application possibilities.

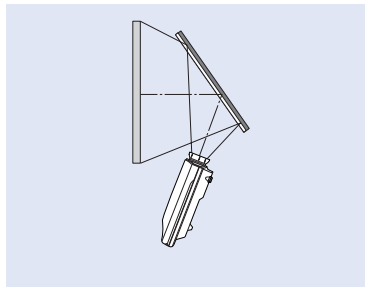

Rear Projection System

Twin Stacking Capability

When applications require double the light output, the VPL-FX52 can be twin-stacked^{*3}. Pictures from the two projectors are then matched using the Picture Shift function on each unit.

^{*3} The optional VPLL-FM21 projection lens cannot be used when the VPL-FX52 or VPL-FX52L are stacked.

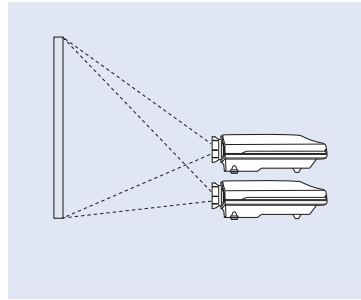

Twin Stacking

Variety of Inputs

The VPL-FX52 accepts a wide variety of input signals, including composite and component video, S-Video (Y/C), and HDTV, as well as computer signals up to UXGA (fv: 60 Hz), expanding its system-connection possibilities. It also has a DVI-D input, to take advantage of the standard for the direct transfer of digital signals from a PC or a workstation. And because the projector is equipped with five BNC connectors, signals can be input from sources located far away from the projector.

Digital Keystone Adjustment

Keystone distortion of up to ± 20 degrees can be digitally corrected via the OSD. This enables detailed images to be projected with their correct geometry, even when installation space is limited.

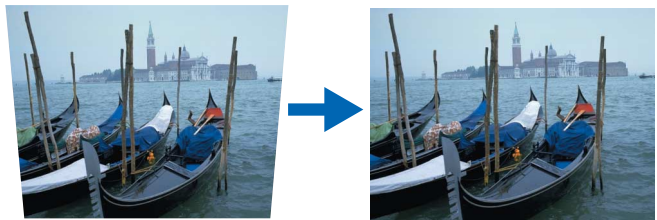

(simulated image)

Direct Power On

Activating this function enables you to skip standby mode and activate the VPL-FX52 immediately. Direct Power On is ideal for large-scale facilities such as museums, auditoriums, and conference halls, with images ready for projection as soon as you turn on the circuit-breaker switch on the switchboard.

Variety of Optional Lenses

The VPL-FX52 is supplied with a power lens as standard. If a specific application requires a special lens, the VPL-FX52L, which is not equipped with a lens, is an excellent choice, as there are three alternative lens types available as options. This choice of lenses enables the VPL-FX52L to be installed in a wide range of applications – from long-distance projection in large auditoriums to short-distance rear-projection applications.

	Projection Lens	Projection Lens	Projection Lens		
	Short-focus Fixed Lens	Short-focus Zoom Lens	Long-focus Zoom Lens		
	VPLL-FM21	VPLL-ZM31	VPLL-ZM101		
					
F	2.0	1.9-2.0	2.0-2.6		
Throw ratio*1	0.9:1	1.55-1.7:1	3.3-5.0:1		
Zoom	—	x 1.1	x 1.5		
Throwing Distance					
Screen size*2		Wide	Tele	Wide	Tele
40-inch	690 mm	1190 mm	1250 mm	2600 mm	3890 mm
60-inch	1080 mm	1840 mm	1940 mm	4000 mm	5940 mm
80-inch	1460 mm	2490 mm	2620 mm	5410 mm	7980 mm
100-inch	1850 mm	3150 mm	3300 mm	6810 mm	10030 mm
120-inch	2240 mm	3800 mm	3980 mm	8220 mm	12080 mm
150-inch	2820 mm	4780 mm	5000 mm	10330 mm	15150 mm
200-inch	3780 mm	6410 mm	6710 mm	13840 mm	20270 mm
250-inch	4750 mm	8050 mm	8410 mm	17350 mm	25380 mm
300-inch	5720 mm	9680 mm	10120 mm	20870 mm	30500 mm

*1 Distance between the center of the projector lens and the screen, divided by the screen width.

*2 Viewable area, measured diagonally.

Network Capability

Because the VPL-FX52 is equipped with a 10Base-T/100Base-TX Ethernet interface and complies with TCP/IP protocols, a number of network-based functions can be performed from a PC on the same network. For example, from a web browser, the projector's current status can be verified and simple control, such as powering the unit on or off, can be performed. Also, the system can be set up to send automatic e-mail reports to designated recipients for scheduled maintenance, including projected lamp life and error reports.

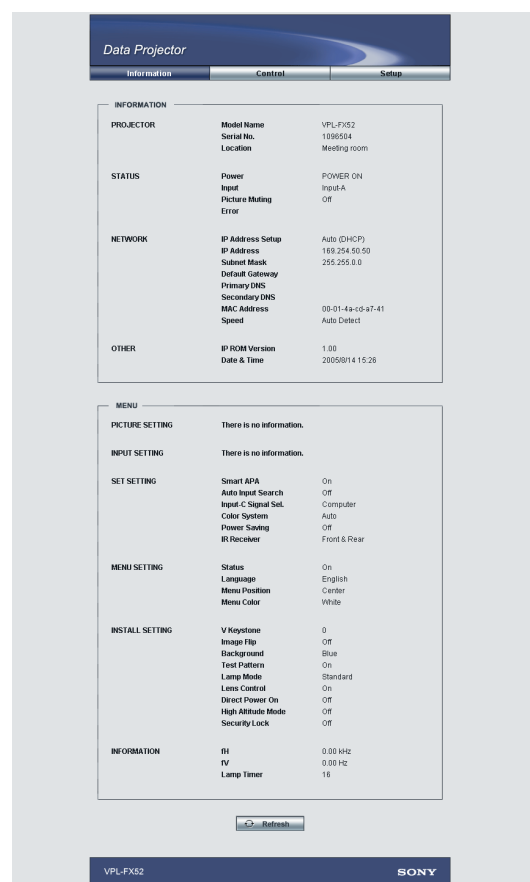

The screenshot displays the 'Data Projector' web interface. At the top, there are tabs for 'Information', 'Control', and 'Setup'. The 'Information' tab is active, showing a table of projector details:

Category	Item	Value
PROJECTOR	Model Name	VPL-FX52
	Serial No.	198554
	Location	Meeting room
STATUS	Power	POWER ON
	Input	Input-A
	Picture Mating Error	Off
NETWORK	IP Address Setup	Auto (DHCP)
	IP Address	193.254.50.50
	Subnet Mask	255.255.0.0
	Default Gateway	
	Primary DNS	
	Secondary DNS	
	MK Address	00-01-4a-c5-a7-41
Speed	Auto Detect	
OTHER	IP ROM Version	1.00
	Date & Time	2005/01/14 15:26

Below the information table is a 'MENU' section with various settings:

- PICTURE SETTING:** There is no information.
- INPUT SETTING:** There is no information.
- SET SETTING:**
 - Smart APA: On
 - Auto Input Search: Off
 - Input C Signal Sel.: Computer
 - Color System: Auto
 - Power Saving: Off
 - IR Receiver: Front & Rear
- MENU SETTING:**
 - Status: On
 - Language: English
 - Menu Position: Center
 - Menu Color: White
- INSTALL SETTING:**
 - V Keystroke: 0
 - Image Flip: Off
 - Background: Blue
 - Test Pattern: On
 - Lamp Mode: Standard
 - Lens Control: On
 - Direct Power On: Off
 - High Altitude Mode: Off
 - Security Lock: Off
- INFORMATION:**
 - Hz: 0.00 kHz
 - Hz: 0.00 Hz
 - Lamp Timer: 16

At the bottom of the menu section is a 'Refresh' button. The footer of the interface shows 'VPL-FX52' on the left and the 'SONY' logo on the right.

Multi-Function Remote Commander Unit

The supplied Remote Commander™ Unit is useful for both setting up the projector and delivering presentations. Functions such as input selection, lens control, Digital Zoom, and Freeze can be performed from this wireless Remote Commander Unit.



Digital Zoom and Freeze Functions

With the 4-times Digital Zoom function, one section of a presentation can be zoomed in for a closer look and to convey a message more clearly. And for smart presentations, the Freeze function displays a freeze-frame while a presenter prepares or switches to the next image.

Smart APA (Auto Pixel Alignment)

The Smart APA function automatically sizes and adjusts PC image displays for optimum picture performance allowing users to concentrate on their presentations, rather than time-consuming technical adjustments.

Password-Authorization Protection

This function restricts unauthorized use of the projector. Once a password has been set, the VPL-FX52 cannot be used without it.

Multi-Language OSD

The OSD for projector control is available in nine languages: English, Dutch, French, Italian, German, Spanish, Japanese, Chinese, and Korean. Its position and color can be altered, depending on user preferences.

OPTIONAL ACCESSORIES



LMP-F300
Projector Lamp
(for replacement)



PSS-620
Suspension Support



RM-PJK1
Presentation Tool

Preset Signal Chart**

No.	Resolution	fH (kHz)	fV (Hz)	Sync (H/V)		
1	Video 60 Hz	15.734	59.940	N/N		
2	Video 50 Hz	15.625	50.000	N/N		
3	15k RGB/Component 60 Hz	15.734	59.940	S on G/Y or Composite sync		
4	15k RGB/Component 50 Hz	15.625	50.000			
5	HDTV	33.750	60.000			
6*	640 x 350	VGA mode 1	31.469		70.086	P/N
7*		VGA VESA 85 Hz	37.861		85.080	P/N
8*	640 x 400	PC-9801 Normal	24.823	56.416	N/N	
9*		VGA mode 2	31.469	70.086	N/P	
10*		VGA VESA 85 Hz	37.861	85.080	N/P	
11*		VGA mode 3	31.469	59.940	N/N	
12*	640 x 480	Macintosh 13"	35.000	66.667	N/N	
13*		VGA VESA 72 Hz	37.861	72.809	N/N	
14*		VGA VESA 75 Hz	37.500	75.000	N/N	
15*		VGA VESA 85 Hz	43.269	85.008	N/N	
16*		800 x 600	SVGA VESA 56 Hz	35.156	56.250	P/P
17*	SVGA VESA 60 Hz		37.879	60.317	P/P	
18*	SVGA VESA 72 Hz		48.077	72.188	P/P	
19*	SVGA VESA 75 Hz		46.875	75.000	P/P	
20*	SVGA VESA 85 Hz		53.674	85.061	P/P	
21*	832 x 624	Macintosh 16"	49.724	74.550	N/N	
22*	1,024 x 768	XGA VESA 43 Hz	35.524	86.958	P/P	
23*		XGA VESA 60 Hz	48.363	60.004	N/N	
24*		XGA VESA 70 Hz	56.476	69.955	N/N	
25*		XGA VESA 75 Hz	60.023	75.029	P/P	
26*		XGA VESA 85 Hz	68.677	84.997	P/P	
27*	1,152 x 864	SXGA VESA 70 Hz	63.995	70.019	P/P	
28		SXGA VESA 75 Hz	67.500	75.000	P/P	
29		SXGA VESA 85 Hz	77.487	85.057	P/P	
30*	1,152 x 900	Sunmicro LO	61.795	65.960	N/N	
31		Sunmicro HI	71.713	76.047	Composite sync	
32*	1,280 x 960	SXGA VESA 60 Hz	60.000	60.000	P/P	
33		SXGA VESA 75 Hz	75.000	75.000	P/P	
34*	1,280 x 1,024	SXGA VESA 43 Hz	46.433	86.872	P/P	
35		SGL-5	53.316	50.062	S on G	
36*		SXGA VESA 60 Hz	63.974	60.013	P/P	
37		SXGA VESA 75 Hz	79.976	75.025	P/P	
38		SXGA VESA 85 Hz	91.146	85.024	P/P	
39	1,600 x 1,200	UXGA VESA 60 Hz	75.000	60.000	-	
43	480/60P	480/60P (Double frequency NTSC)	31.470	60.000	S on G	
44	575/50P	575/50P (Double frequency PAL)	31.250	50.000	S on G	
45	1,080/50I	1,080/50I	28.130	50.000	-	
47	720/60P	720/60P	45.000	60.000	-	
48	720/50P	720/50P	37.500	50.000	-	
50	540/60P	540/60P	33.750	60.000	-	
52	1,400 x 1,050	SXGA+	63.981	60.020	N/N	

*Digital input is supported for the signals marked with an asterisk.

**If you would like to input a signal that is not listed in the above chart, please contact your local Sony sales office.

Installation Diagrams

(When using the VPL-FX52 with supplied lens)

Floor Installation

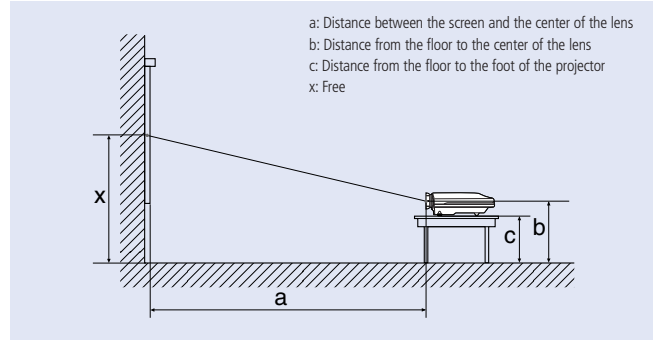

Screen size*	40	60	80	100	120	150	200	250	300		
a	min	mm (inches)	1490 (58 3/4)	2280 (89 7/8)	3060 (120 1/2)	3850 (151 5/8)	4630 (182 3/8)	5810 (228 7/8)	7770 (306)	9730 (383 1/8)	11690 (460 3/8)
	max	mm (inches)	1820 (71 3/4)	2780 (109 1/2)	3740 (147 3/8)	4700 (185 1/8)	5660 (222 7/8)	7100 (279 5/8)	9500 (374 1/8)	11900 (468 5/8)	14300 (563 1/8)
b	min	mm (inches)	x-305 (x-12 1/8)	x-457 (x-18)	x-610 (x-24 1/8)	x-762 (x-30)	x-914 (x-36)	x-1143 (x-45)	x-1524 (x-60)	x-1905 (x-75 1/8)	x-2286 (x-90 1/8)
	max		x								
c	min	mm (inches)	x-417 (x-16 1/2)	x-569 (x-22 1/2)	x-722 (x-28 1/2)	x-874 (x-34 1/2)	x-1026 (x-40 1/2)	x-1255 (x-49 1/2)	x-1636 (x-64 1/2)	x-2017 (x-79 7/16)	x-2398 (x-94 1/2)
	max	mm (inches)	x-102 (x-4 1/8)								

* Viewable area, measured diagonally.

Ceiling Mount Installation

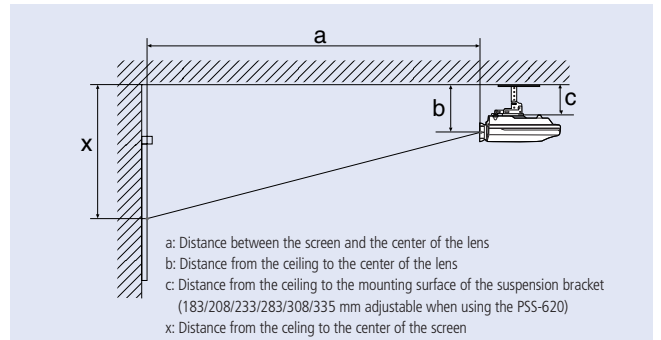

Screen size*	40	60	80	100	120	150	200	250	300		
a	min	mm (inches)	1490 (58 3/4)	2280 (89 7/8)	3060 (120 1/2)	3850 (151 5/8)	4630 (182 3/8)	5810 (228 7/8)	7770 (306)	9730 (383 1/8)	11690 (460 3/8)
	max	mm (inches)	1820 (71 3/4)	2780 (109 1/2)	3740 (147 3/8)	4700 (185 1/8)	5660 (222 7/8)	7100 (279 5/8)	9500 (374 1/8)	11900 (468 5/8)	14300 (563 1/8)
b	min	mm (inches)	c+91.4 (c+3 5/8)								
	max	mm (inches)	c+101.4 (c+4)								
x	min	mm (inches)	c+100 (c+4)								
	max	mm (inches)	c+406 (c+16)	c+558 (c+22)	c+711 (c+28)	c+863 (c+34)	c+1015 (c+40)	c+1244 (c+49)	c+1625 (c+64)	c+2006 (c+79)	c+2387 (c+94)

* Viewable area, measured diagonally.

SPECIFICATIONS

	VPL-FX52 (standard lens)	VPL-FX52L (lens is not supplied)
Optical		
Projection system	3 LCD panels, 1 lens projection system	
LCD panel	1.3-inch TFT Sony LCD panel with Micro Lens Array, 2,359,296 (1024 x 768 x3) pixels	
Projection lens	Approx. 1.3 times zoom lens f50.8 to 64.0 mm, F 1.7 to 2.0	Not supplied
Lamp	300 W Lamp	
Screen coverage	40 to 300 inches (viewable area measured diagonally)	
Light output	6000 ANSI lumens (lamp mode high), 5100 ANSI lumens (lamp mode standard)	
Signals		
Color system	NTSC 3.58, PAL, SECAM, NTSC 4.43, PAL-M, PAL-N (automatically/manually selected)	
Resolution	Video : 750 TV lines, RGB : 1024 x 768 pixels	
Acceptable computer signal	fH : 19 to 92 KHz, fV : 48 to 92 Hz (Up to UXGA 60 Hz)	
Acceptable video signal	15k RGB 50/60 Hz, Progressive Component 50/60 Hz, DTV (480/60i, 575/50i, 480/60p, 575/50p, 1080/50i, 720/60p, 720/50p, 540/60p), Composite Video, Y/C Video	
General		
Dimension (WxHxD)	420 x 169 x 502 mm (19 x 6 5/8 x 19 7/8 inches)	420 x 169 x 464 mm (19 x 6 5/8 x 18 3/8 inches)
Mass	Approx. 10.5 kg (23 lbs 4 oz)	Approx. 9.1 kg (20 lbs 1 oz)
Power requirements	AC 100 to 240 V, 50/60 Hz	
Power consumption	Max. 400 W, Standby 7 W	
Heat dissipation	1365 BTU	
Operating temperature	0 to 35 °C (32 to 95 °F)	
Operating humidity	35 to 85% (no condensation)	
Storage temperature	-20 to 60 °C (-4 to 140 °F)	
Storage humidity	10 to 90%	
Inputs/Outputs		
Video IN	Video	BNC
	S Video	Y/C Mini DIN 4-pin
Video OUT	Video	Loop-through BNC type
	S Video	Loop-through mini DIN 4-pin (male)
Input A	RGB	Analog RGB : HD D-sub 15-pin (female)
Input B	RGB	Digital RGB : DVI-D (TMDS)
Input C	RGB	Analog RGB/component : 5 BNC (female)
Monitor out		HD D-sub 15-pin (female)
TRIG		Mini jack
RS-232C		D-sub 9 pin (female)
CONTROL S IN		Stereo mini jack, 5 Vp-p, plug-in-power
Network		RJ-45 : 10Base-T/100Base-TX
Supplied Accessories		
	Remote Commander Unit, Size AA (R6) Batteries (x2), Lens Cap (VPL-FX52 only), AC Power Cord, Air Filter, Operating Instructions and Installation Manual for Dealers (CD-ROM), Quick Reference Manual, Safety Regulations, Security Label, Warranty Card	

DIMENSIONS

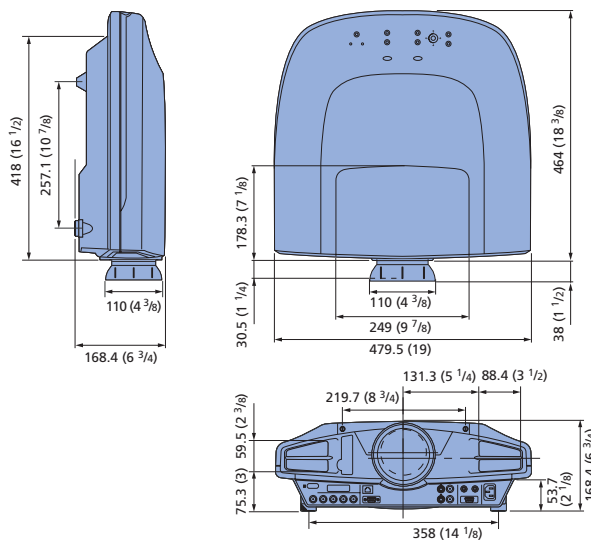

Unit: mm (inches)



Lead-free solder is used for soldering all parts including circuit component electrodes.
Halogenated flame retardants are not used in cabinets.
Packaging cushions do not use polystyrene foam.

Distributed by

© 2005 Sony Corporation. All rights reserved.
Reproduction in whole or in part without written permission is prohibited.
Features and specifications are subject to change without notice.
All non-metric weights and measurements are approximate.
Projected images in this brochure are simulated.
Sony is a registered trademark of Sony Corporation.
Remote Commander is a trademark of Sony Corporation.
All other trademarks are the property of their respective owners.